

---

MANUAL PART NUMBER: 400-0208-001

## **TNP100-HB**

### **Tilt 'N Plug™ Interconnect Box**

### **USER'S GUIDE**

## TABLE OF CONTENTS

	<b>Page</b>
PRECAUTIONS / SAFETY WARNINGS.....	2
GENERAL .....	2
INSTALLATION .....	2
CLEANING .....	2
FCC / CE NOTICE.....	2
ABOUT YOUR <b>TNP100-HB</b> .....	3
TECHNICAL SPECIFICATIONS .....	3
<b>TNP100-HB</b> DIMENSIONS .....	4
DIAGRAMS 1A-1D.....	4
DESCRIPTION DIAGRAM .....	5
DIAGRAM 2.....	5
APPLICATION DIAGRAM.....	5
DIAGRAM 3.....	5
DIAGRAM 4.....	6
DIAGRAM 5.....	7
INSTALLATION .....	8
OPERATION.....	9
FREQUENTLY ASKED QUESTIONS (FAQ) .....	9
ACCESSORIES.....	10
TROUBLESHOOTING GUIDE.....	10
ALTINEX POLICY.....	11
LIMITED WARRANTY .....	11
RETURN POLICY.....	11
CONTACT INFORMATION.....	11

## PRECAUTIONS / SAFETY WARNINGS 1

Please read this manual carefully before using your **TNP100-HB** Interconnect Box. Keep this manual handy for future reference. These safety instructions are to ensure the long life of your **TNP100-HB** and to prevent fire and shock hazard. Please read them carefully and heed all warnings.

### 1.1 GENERAL

- Unauthorized personnel shall not open the unit since there are high-voltage components inside.
- Qualified ALTINEX service personnel, or their authorized representatives must perform all service.

	<b>CAUTION</b> RISK OF ELECTRIC SHOCK DO NOT OPEN
The lightning flash and arrowhead within the triangle is a warning sign alerting you of "dangerous voltage" inside the product.	CAUTION: TO REDUCE RISK OF ELECTRIC SHOCK, DO NOT REMOVE COVER (OR BACK) NO USER SERVICEABLE PARTS INSIDE.

### 1.2 INSTALLATION

- For best results, place the **TNP100-HB** Interconnect Box in a dry area away from dust and moisture.
- To prevent fire or shock, do not expose this unit to rain or moisture. Do not place the **TNP100-HB** Interconnect Box in direct sunlight, near heaters or heat radiating appliances, or near any liquid. Exposure to direct sunlight, smoke, or steam can harm internal components.
- Handle the **TNP100-HB** Interconnect Box carefully. Dropping or jarring can damage internal components.
- Never place fingers inside the opening on each side of the unit. This action could

cause serious injury because of the sharp edges inside of the **TNP100-HB**.

- Do not place heavy objects on top of the **TNP100-HB**. Do not use excessive force to push down on the top of the unit.
- To turn off the main power, disconnect the power cord, which powers the power socket on the **TNP100-HB** pop up panel. The power outlet socket should be installed as near to the equipment as possible, and should be easily accessible.
- We recommend using wall outlets with a Ground Fault Circuit Interrupter (GFCI) for maximum protection.
- Install all cables according to the instructions. Do not force or pull out any cable or power cord that is attached to the **TNP100-HB** Interconnect Box.

### 1.3 CLEANING

- Surfaces should be cleaned with a dry cloth. Never use strong detergents or solvents, such as alcohol or thinner. Do not use a wet cloth or water to clean the unit.

### 1.4 FCC / CE NOTICE

- This device complies with part 15 of the FCC Rules. Operation is subject to the following two conditions: (1) This device may not cause harmful interference, and (2) this device must accept any interference received, including interference that may cause undesired operation.
- This equipment has been tested and found to comply with the limits for a Class A digital device, pursuant to Part 15 of the FCC Rules. These limits are designed to provide reasonable protection against harmful interference when the equipment is operated in a commercial environment. This equipment generates, uses, and can radiate radio frequency energy and, if not installed and used in accordance with the instruction manual, may cause harmful interference to radio communications.

Operation of this equipment in a residential area is likely to cause harmful interference in which case the user will be required to correct the interference at his own expense.

- Any changes or modifications to the unit not expressly approved by ALTINEX, Inc. could void the user's authority to operate the equipment.

## ABOUT YOUR TNP100-HB 2

The **TNP100-HB** is designed for installation into a conference room table. The **TNP100-HB Tilt 'N Plug™** Interconnect Box provides a means of connecting audio, video, control, and computer video sources into a presentation system. It is ideal for use together with ALTINEX computer video interfaces. The **TNP100-HB Tilt 'N Plug™** Interconnect Box can either pop up and "tilt" to a raised position to provide access to the connectors or it can be lowered into a table when not in use. A pneumatic shock inside the **TNP100-HB's** tower type construction applies pressure to the panel mechanism, making it easy to raise and secure the unit firmly in an open position. Also, for safety, the chassis of the **TNP100-HB** is connected to the ground pin of the power plug.

The **Tilt 'N Plug™** Interconnect Box has one input plate on the front panel of the unit. The standard plate offers Computer Video (15-pin HD); Audio (Stereo Mini), Modem (RJ-11), Network (RJ-45) and Microphone (XLR 4-pin) input connections. All signals are passed through to a set of female connectors or cables. Several optional connectors can be substituted for the standard set of connectors. For additional information regarding optional connectors, contact the ALTINEX Sales Department.

The **Tilt 'N Plug™** Interconnect Box is designed for use with tables ranging from one to three inches thick. The **Tilt 'N Plug™** comes in a standard matte black color; however, it can be finished to match the table. This is available on a custom per order basis at an additional charge.

## TECHNICAL SPECIFICATIONS 3

FEATURES/DESCRIPTION	TNP100-HB	
<b>GENERAL</b>		
<b>Front Panel Standard Configuration Connectors</b>	<b>Faceplate</b>	<b>Cable end under table</b>
Power	1 outlet with one circuit breaker	1 plug with 6ft cord
Computer Video	1 15-pin HD-F	1 15-pin HD-F
Audio	1 3.5mm stereo female jack	1 3.5mm stereo male plug
Telephone	1 RJ-11 F (6-position)	1 RJ-11-M (6-position)
Network	1 RJ-45-F (8-position)	1 RJ-45-M (8-position)
Microphone	XLR 4-pin male receptacle	XLR 4-pin female plug

Table 1. **TNP100-HB** General

MECHANICAL	TNP100-HB
Width (inches)	6.03in (153mm)
Height (closed)	4.79in (122mm)
Height (opened)	8.05in (205mm)
Depth (inches)	7.56in (192mm)
Finish	Flat Black
T° Operating	10°C-35°C
T° Maximum	50°C
Humidity	90% non-condensing

Table 2. **TNP100-HB** Mechanical

ELECTRICAL	TNP100-HB
<b>Power</b>	
Power Rating (pass through connector)	90-140 VAC, 5Amps Max

Table 3. **TNP100-HB** Electrical

## TNP100-HB DIMENSIONS 4

Diagrams: 1A, 1B, 1C, & 1D

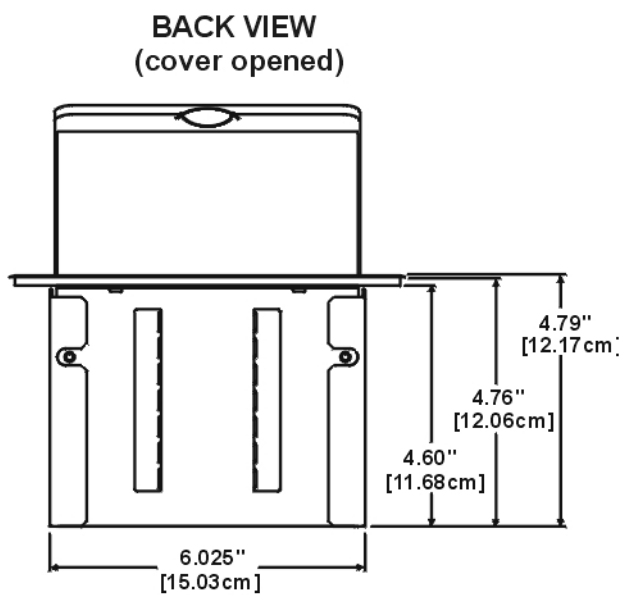
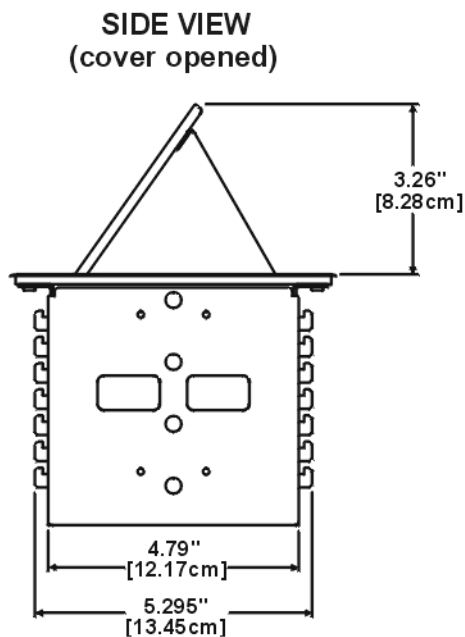
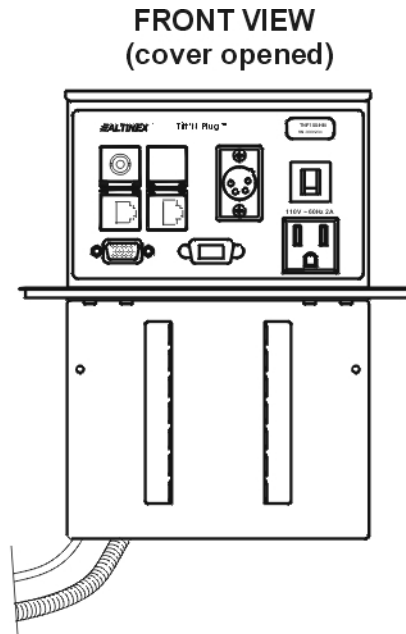
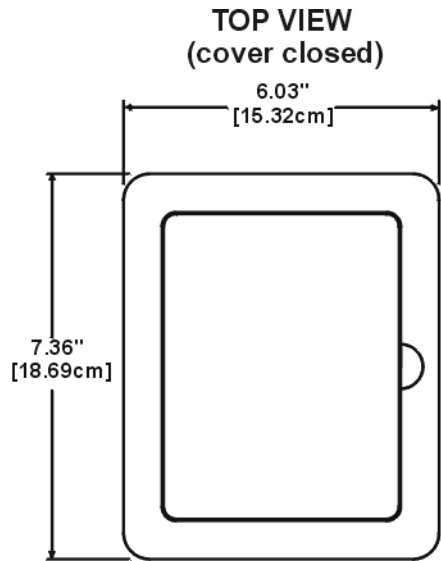

## DESCRIPTION DIAGRAM 5

**Diagram 2: TNP100-HB Faceplate**

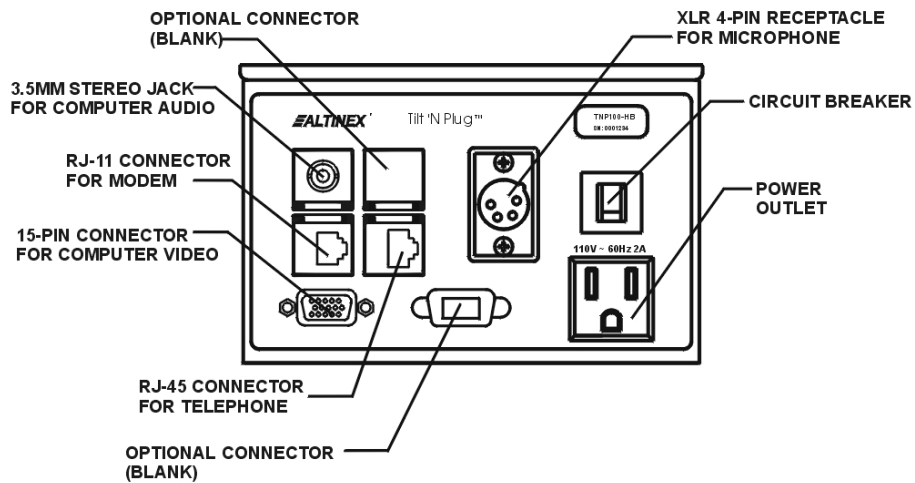

## APPLICATION DIAGRAM 6

**Diagram 3: Application**

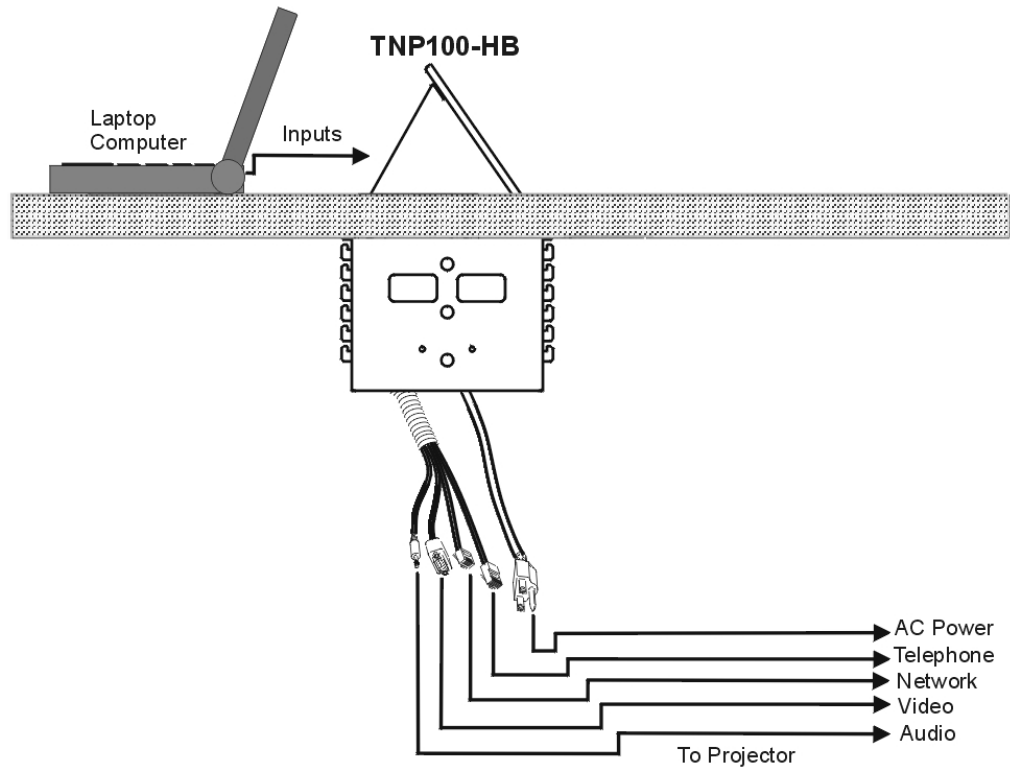
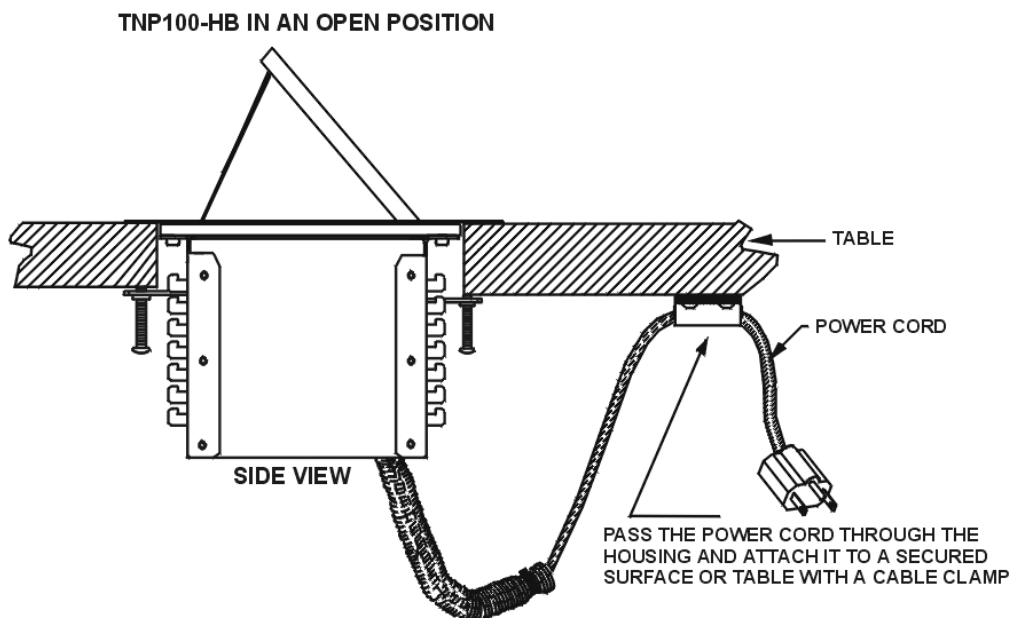
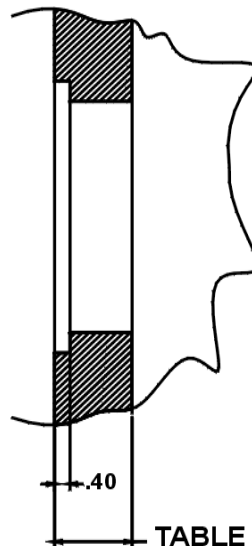
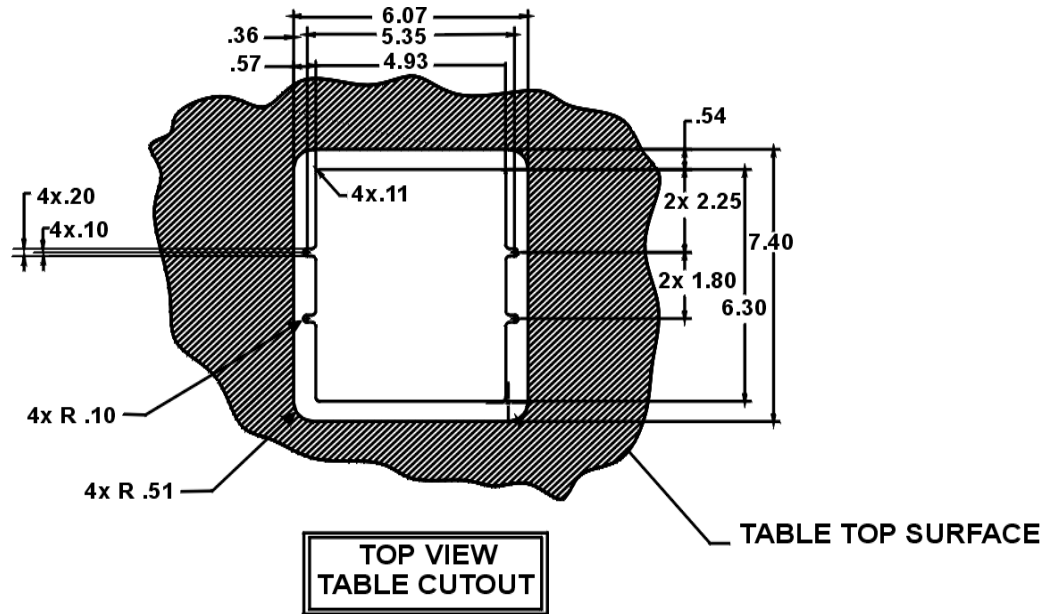

Diagram 4: Final Installation



NOTE: THE DIAGRAM OF THE SIDE VIEW ABOVE SHOWS ONLY THE POWER CORD NOT THE CABLES

**Diagram 5: Table Cutout Requirements**



TOLERANCE:  $\pm .03$

**NOTE:** Specifications subject to change without notice. Always confirm measurements before cutting to insure that specifications have not changed. Always make sure to orient cutout in direction necessary for proper operation of the installed unit.



## INSTALLATION 7

- Step 1.** Cut an opening into the table's surface. Refer to diagram 5 on page 7 of the manual for table cutout requirements.  
Note: The table can be 3 inches or thinner in thickness. Always confirm dimensions before cutting to insure that specifications have not changed.
- Step 2.** Insert the **TNP100-HB** into the opening in the table.
- Step 3.** Place the support brackets under the table and place them between the support mount grooves on the side of the **TNP100-HB** unit. Attach the brackets to the groove at the desired height and secure them to the bottom of the table using the 6-32 screw. There are two support brackets, one for each side of the unit. (See Figure 1)

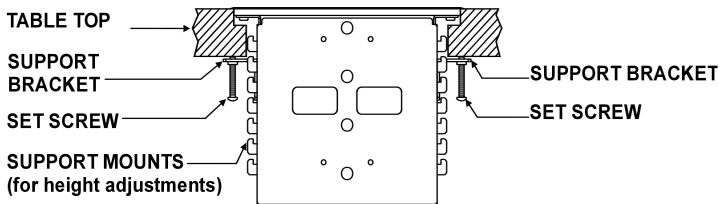

**Figure 1: Attachment of the TNP100 -HB to the table using support brackets and set screws**

- Step 4.** Secure the cables by using the provided cable clamp (See Figure 2). Pass the power cord from the bottom of the housing and attach it to the table using the cable clamp supplied with the **TNP100-HB** unit. Do not keep the cord too tight or too loose (See Diagram 4, page 6).



**Figure 2: Cable Clamp**

- Step 5.** Connect the appropriate cables with the correct input connectors. There are connections for Computer Video (15-pin HD), Audio (Stereo Mini), Modem (RJ-11), Network (RJ-45) and Microphone (XLR 4-pin) on the front panel.
- Step 6.** Once you have applied power and connected the proper cables on the bottom of the unit, you may raise the unit. To raise the **TNP100-HB** into position, lift the top by pulling upward at the notch in the top plate.
- Step 7.** To lower the unit, push on the top of the **TNP100-HB** until it fits into place.

**For more information, please refer to the FAQ Section or the Troubleshooting Guide.**

## OPERATION 8

The **TNP100-HB** unit will operate successfully as long as all cables are attached properly and other technical specifications are maintained.

## FREQUENTLY ASKED QUESTIONS (FAQ) 9

No:	Question	Answer
1.	What happens if the spring breaks?	The unit will not stay open.
2.	What do I do if the <b>TNP100-HB</b> won't stay open?	Replace the gas spring. Call ALTINEX for service information.
3.	How much room is taken up on the underside of the table?	The unit is 4.5 inches deep maximum below the table; to this dimension add about 2.5 inches for cable clearance.
4.	What if my table is thicker than 3 inches?	Then the area under the table near the <b>TNP100-HB</b> must be reduced to 3 inches of thickness.
5.	Does ALTINEX honor any warranty on field modifications?	Anything modified by non-ALTINEX personnel is not covered by warranty.

## ACCESSORIES 10

Model No.	Description
<b>LABELS</b>	
<b>MS8301LB</b>	Input/Output Labels
<b>COVERS</b>	
<b>CVR1001</b>	Cover for PNP/TNP Cutouts
<b>VGA MALE TO MALE (HD-15) HIGH RESOLUTION CABLE</b>	
<b>CB37xxMR</b>	xx = available length of 3ft, 6ft, 15ft, 25ft, 50ft, 75ft, 100ft, 150ft
<b>VGA MALE TO FEMALE (HD-15) HIGH RESOLUTION CABLE</b>	
<b>CB39xxMR</b>	xx = available length of 3ft, 6ft, 15ft, 25ft, 50ft, 75ft, 100ft, 150ft, 200ft, 250ft
<b>SUPER HIGH RESOLUTION PLENUM-FLEX MULTI-CHANNEL COAX CABLE VGA MALE TO VGA MALE (HD-15)</b>	
<b>CB5000PL-5VMxxxVM</b>	xxx = available length of 3ft, 6ft, 15ft, 25ft, 50ft, 75ft, 100ft, 150ft, 200ft, 250ft
<b>SUPER HIGH RESOLUTION PLENUM-FLEX MULTI-CHANNEL COAX CABLE VGA MALE TO VGA FEMALE (HD-15)</b>	
<b>CB5000PL-5VMxxxVF</b>	xxx = available length of 3ft, 6ft, 15ft, 25ft, 50ft, 75ft, 100ft, 150ft, 200ft, 250ft

## TROUBLESHOOTING GUIDE 11

The supplied **TNP100-HB** unit was carefully tested and no problems were detected however, we would like to offer the following suggestions:

- If there is no power, check to see if the circuit breaker is tripped.
- Please make sure that the highest quality video, audio, network, and telephone cables or connectors are used.
- Make sure that no cable or power cord is damaged or pinched. If there has been damage, then do not use the **TNP100-HB** unit. Immediately contact the ALTINEX Customer Service Department to have the unit repaired.

### 12.1 LIMITED WARRANTY

ALTINEX warrants that its products and cables are free from defects in materials under normal use and service. This warranty is limited to repairing at company's factory any part or parts of the product, which upon company's examination shall disclose to be, thus defective. Products considered defective should be returned to company with transportation charges pre-paid within 2 years (90 days for cables) from date of shipment to the purchaser. The warranty is expressly instead of all other warranties expressed or implied. ALTINEX neither assumes nor authorizes any other person to assume for it any other liability concerning the sale of the products. This warranty shall not apply to any product that shall have been repaired or altered outside of company's factory in any way so as, in its judgment, to affect its stability or reliability, or that has been subject to misuse, negligence or accident.

### 12.2 RETURN POLICY

It is very important to ALTINEX that you receive all products that you have ordered and that this product meets your expectations. In the unlikely event that an ALTINEX product needs to be returned, please follow the policies below:

ALTINEX will accept all product returns for a period of 30 days from authorized ALTINEX dealers in an unopened package.

If a product has been opened, the restocking fees will apply. For the restocking fee, please contact an ALTINEX Sales Representative.

If the product is in your possession for more than 30 days, the restocking fees will apply.

ALTINEX will not accept any returns on cables or custom products.

If your product is in warranty and needs service, contact the ALTINEX Sales Department for an RMA (Return Material Authorization). Products

returned without an RMA number may experience a delay in service.

If your product is out of warranty and needs service, contact the ALTINEX Sales Department for an RMA (Return Material Authorization). Products returned without an RMA number may experience a delay in service. The service charges will be quoted to you before the actual repairs are done.

### 12.3 CONTACT INFORMATION

#### ALTINEX, INC.

592 Apollo Street  
Brea, CA 92821 USA

TEL: 714-990-2300

TOLL FREE: 1-800-ALTINEX

WEB: [www.altinex.com](http://www.altinex.com)

E-MAIL: [solutions@altinex.com](mailto:solutions@altinex.com)

FAX: 714-990-3303